

SCAMMELL

Crash Fire Rescue Chassis 6 x 6

Maximum Design Ratings

Front Axle

Rear Axle

GVW

Unladen Chassis/Cab Weight

400 bhp

8130 kg

20320 kg

26410 kg

10450 kg

500 bhp

8130 kg

20320 kg

26450 kg

10780 kg

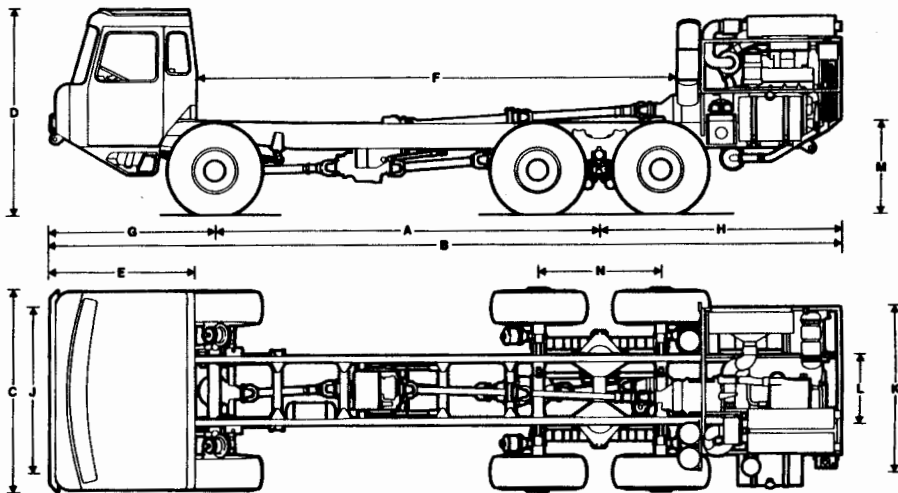

Dimensions (mm)

A. Wheelbase	4750
B. Overall Length	9743
C. Overall Width	2443
D. Overall Height — laden	2562
E. Bumper to Back of Cab	1794
F. Back of Cab to Power Unit	6478
G. Front Overhang	2032

H. Rear Overhang	2961
J. Front Track (at ground)	2010
K. Rear Track (at ground)	2060
L. Frame Width (at rear)	863
M. Frame Height — laden	1147
N. Bogie Spread	1513